



A•mist^{40/80TF} Central Oil Mist collectors with fan

The Absolent type A•mist Oil mist collector features one of the most effective systems in the world for cleaning oil mist. The series of central collector units consists of parallel modules which are dimensioned after the needed air-flow. The advantages of central collectors are a cheaper installation, easier service because of less service points and the possibility to lead the process air through a heat exchanger. Lead for example the process air outside during summer and back into the premises at winter time.

The highest possible collecting efficiency.

The filtered air becomes so clean that it usually can be returned to the premises. This means less loss of energy and a more balanced ventilation.

Extremely low maintenance.

Absolent collectors can usually run for at least one year without requiring a filter change. Moreover, A•mist cassettes can usually be washed.* This results in a low total cost of ownership.

A very reliable filter unit.

The fan, as the only moving component, is placed at the clean-side to minimize wear & tear.

*This does not include HEPA filters.



A•mist^{80TF}

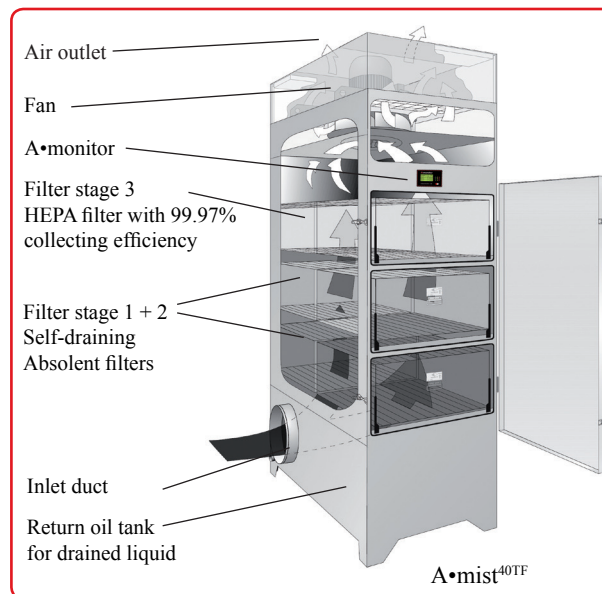

Operation

The filtering process occurs in three stages. The first and second stages consist of self-draining Absolent filter cassettes. The third stage consists of a HEPA-filter, which has a guaranteed and consistent collecting efficiency of 99.97% arresting 0.3 micron dia. particles. The collector unit has an electronic pressure gauge, A•monitor, which shows the pressure drop over the different stages and indicates when a cassette is to be changed. Thanks to the continuous draining of the cassettes, the unit can be operated without interruptions. The return oil is collected at the bottom of the filter for recycling.

Range of Application

The Absolent A•mist is well suited for use in applications such as:

- Grinding (cutting fluid emulsion)
- Turning (cutting fluid emulsion)
- Milling (cutting fluid emulsion)
- Electrical discharge machining
- Machining, using straight oil and moderate loads

Functional design

The A•mist range has a highly robust tower design that occupies a minimum of floor space. Its hinged access doors make service still more convenient. The filter is supplied with a baked powder painted finish that adds colour to the shop floor.

A•mist^{40TF}

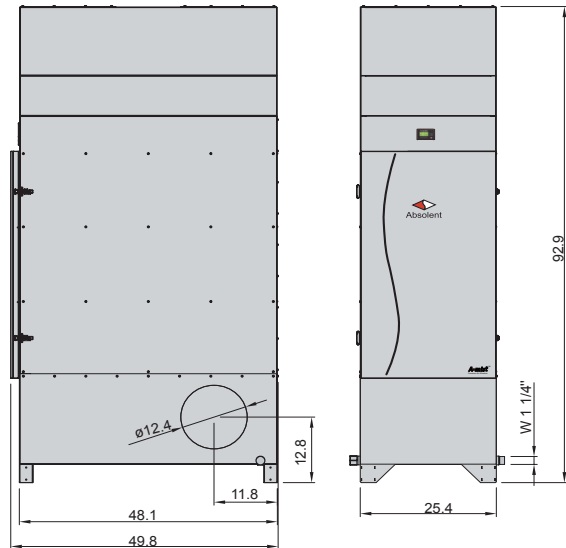

A•mist^{80TF}

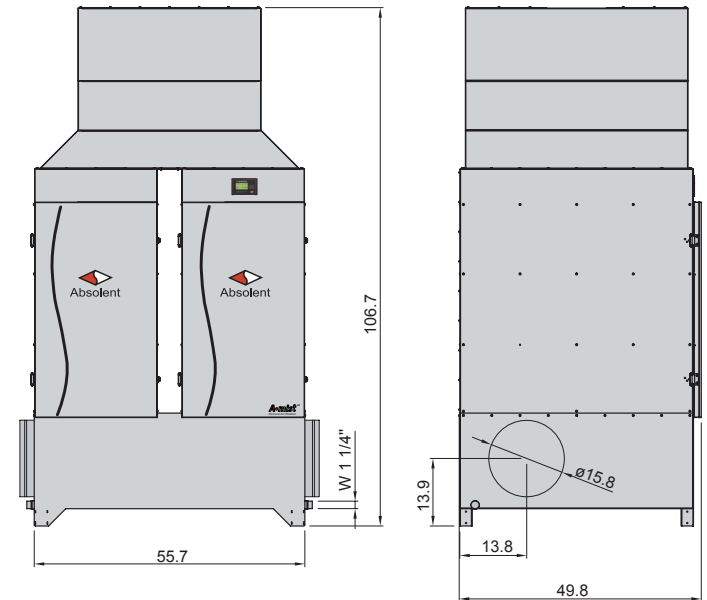

Technical Data

		A•mist ^{40TF}	A•mist ^{80TF}
Max permissible air volume	[cfm]	2350	4700
Filter area, stage 1 (Absolent filter) ²⁾	[ft ²]	308 ¹⁾	616 ¹⁾
Filter area stage 2 (Absolent filter)	[ft ²]	276 ¹⁾	552 ¹⁾
Filter area, stage 3 (HEPA filter)	[ft ²]	440	880
Weight (dry filters)	[lbs]	849	1675
Sound level, 1m in front of filter unit ¹⁾	[dB(A)]	70 ¹⁾	73 ¹⁾
Available dim. ext. pressure drop	[in WC]	5.6	5.6

Fan Data

Motor output	[hp]	5.4	10
Power supply	[V]	480	480
Rated current (3-Phase)	[A]	7.5	13.8

¹⁾ Sound absorption in premises=2153ft², Hemispherical sound propagation. For sound calculation concerning a specific room, contact us at Absolent or any of our dealers.

²⁾ The filter area varies for different applications.

Standard Equipment

- RAL 7035 fine structure
Other colours on request!
- Electronic manometer with the following features:
 - ✓ Pressure drop and operation hour meters
 - ✓ Optical indication of filter alarm (LED).
 - ✓ Digital output signal for remote supervision.

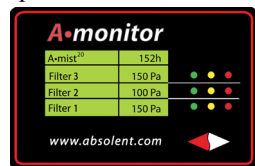

Accessories

- Motor starter for fan for automatic or external starting)
- Frequency controll for the fan with constant flow control
- Outlet hood for channel interface ø15.7 resp. ø19.7
- Carbon filter
- Duct connections for steel or plastic ductwork
- Extension legs, standard height 19.7 in.
- Water trap for various connections of the return oil pipe
- Pump unit for pumping the return oil from the filter.
- Sound insulation
- Extra outlet silencer
- Special colours

Unique filter cassettes



Absolent is one of few companies in this line of business that has specialized in the filtration of air containing wet particles.

This has given us the opportunity to develop a filter cassette that offers a long useful life with consistently high separation efficiency.

Absolent Inc.
8601 Six Forks Road, Suite 400
Raleigh, NC 27615
USA
Phone: +1 (919) 882 2075
Fax: +1 (919) 882 2087
E-mail: info@absolent.com
Sweden • USA • China



www.absolent.com

Dealer:

